

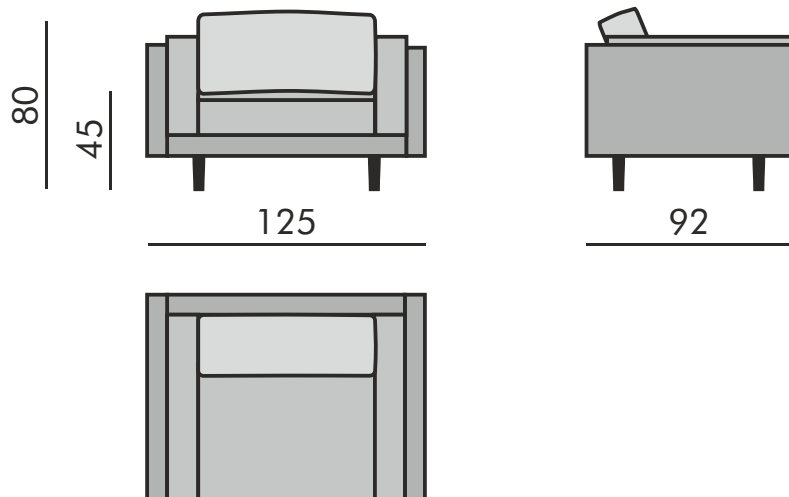

1.5

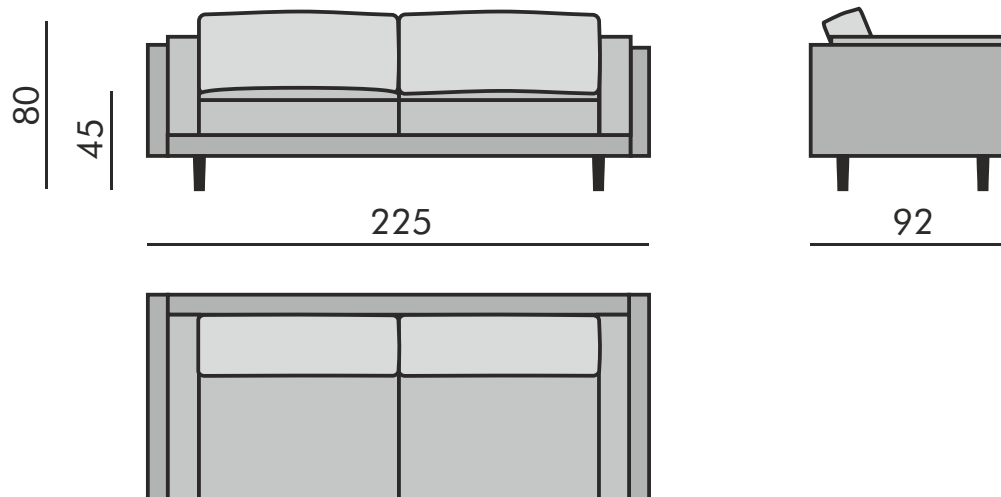

3



B R O N X



- A. SEAT FILLING
- B. BACK FILLING
- C. FRAME SPRINGS/BELTS
- D. FRAME MATERIAL
- E. BACK MATERIAL
- F. UPHOLSTERY
- G. LEGS

- A. POLYURETHANE FOAM T3030,
POLYURETHANE FOAM T3045,
SILICONE BALLS LUX MIXED WITHFOAM STICKS
- B. SILICONE BALLS LUX MIXED WITH FOAM STICKS
- C. SPRINGS
- D. SOLID BEECH WOOD
- E. WOOD BASED ELEMENTS (CHIPBOARD, FIBREBOARD)
OF FRAME
- F. FABRIC AND LEATHER

- G. WOODEN LEGS
H: 15CM

