

MODALTO RESERVES THE RIGHT TO CHANGE CONSTRUCTION OF PRODUCTS AND COMPONENTS USED DUE TO IMPROVING DURABILITY OF PRODUCT AND CUSTOMERS SATISFACTION WITHOUT ANY FURTHER NOTICE.
 EXPLICIT +/- 2CM TOLERANCE OF ALL AELEMENTS SIZES.

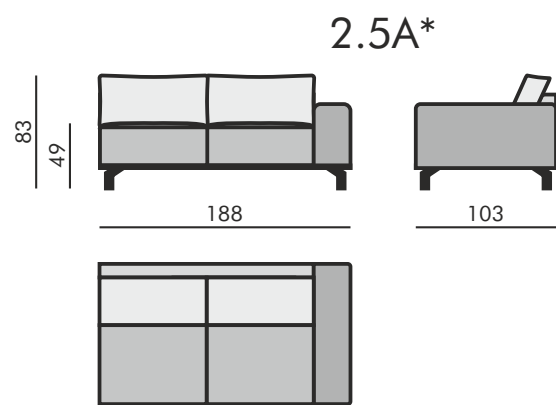

BROOKLYN

* CAN CHOOSE LEFT OR RIGHT SIDE OF THE ARMREST

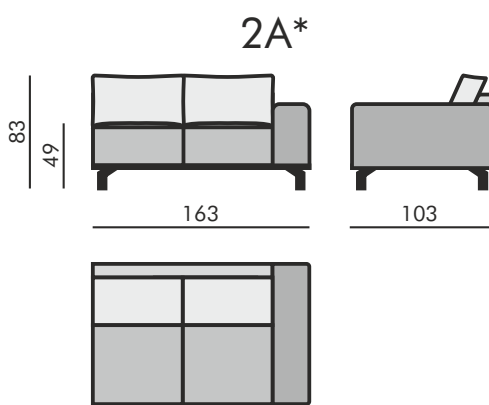
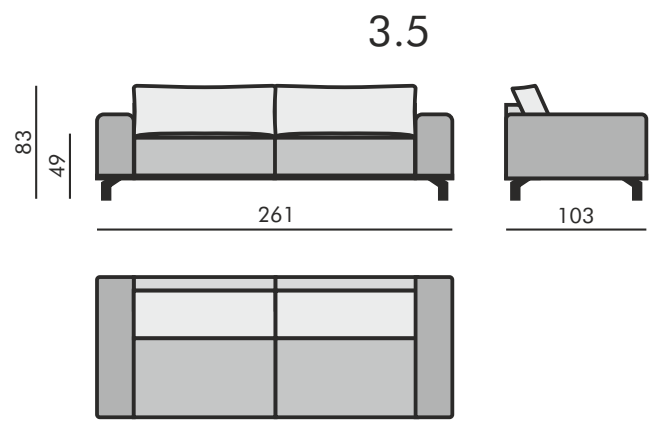
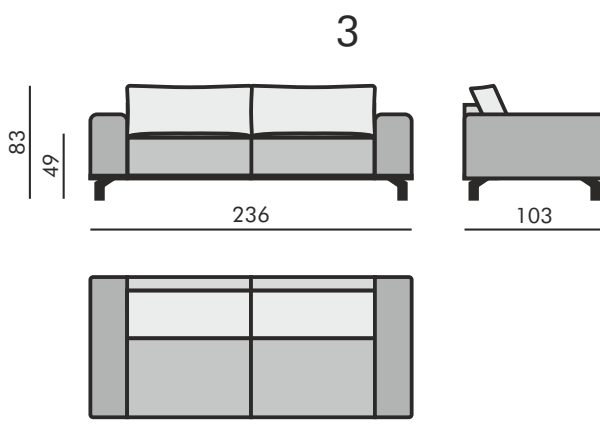
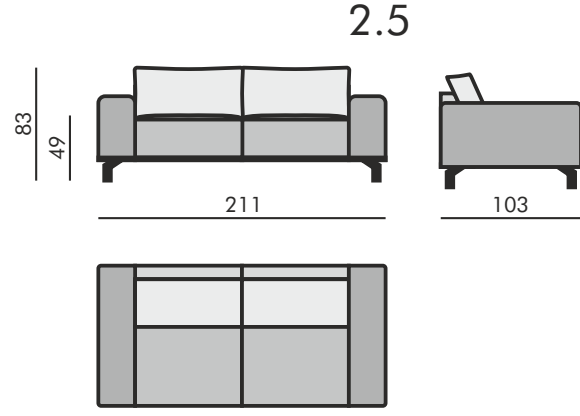
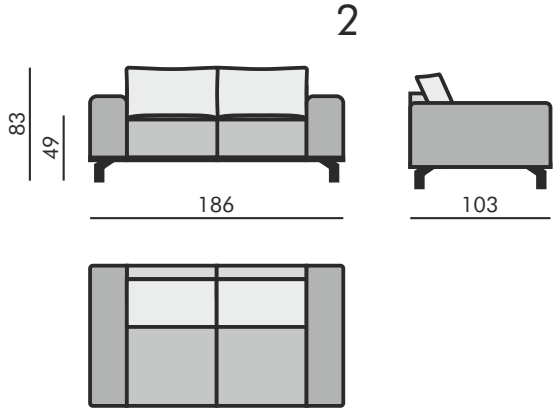
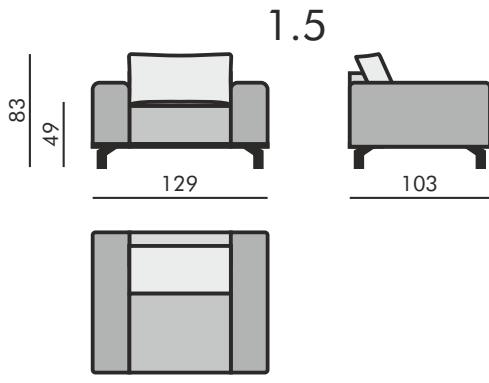

- A. SEAT FILLING
- B. BACK FILLING
- C. FRAME SPRINGS/BELTS
- D. FRAME MATERIAL
- E. BACK MATERIAL
- F. UPHOLSTERY
- G. LEGS

- A. POLYURETHANE FOAM T3045 AND HR3536, BOXSPRING, SILICONE BALLS LUX MIXED WITH FOAM STICKS
- B. SILICONE BALLS LUX MIXED WITH FOAM STICKS
- C. SPRINGS
- D. SOLID BEECH WOOD
- E. WOOD BASED ELEMENTS (CHIPBOARD, FIBREBOARD) OF FRAME
- F. FABRIC AND/OR LEATHER

- G. METAL LEGS
- H: 14CM

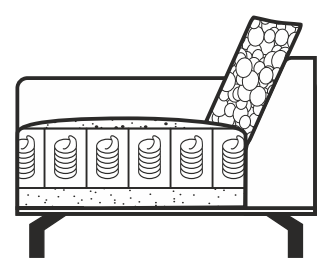

MODALTO RESERVES THE RIGHT TO CHANGE CONSTRUCTION OF PRODUCTS AND COMPONENTS USED DUE TO IMPROVING DURABILITY OF PRODUCT AND CUSTOMERS SATISFACTION WITHOUT ANY FURTHER NOTICE.
 EXPLICIT +/- 2CM TOLERANCE OF ALL AELEMENTS SIZES.

3A*

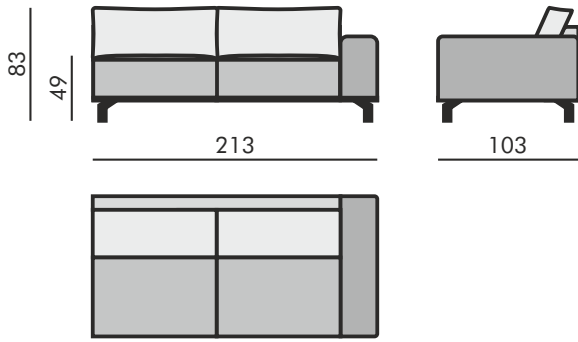

EK*

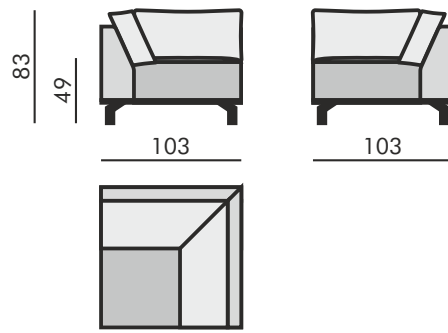

LCH1*

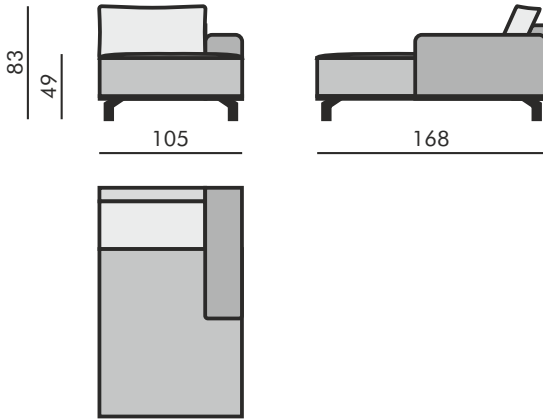

LCH2*

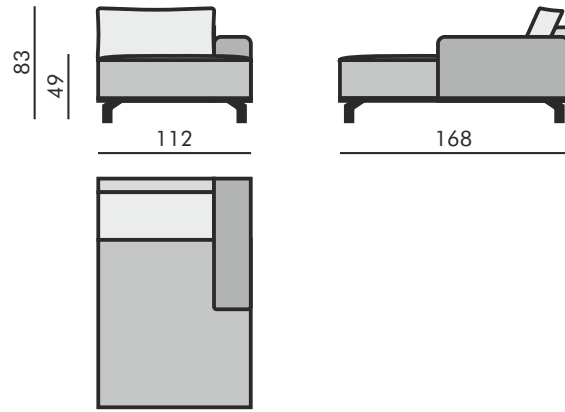

OTT*

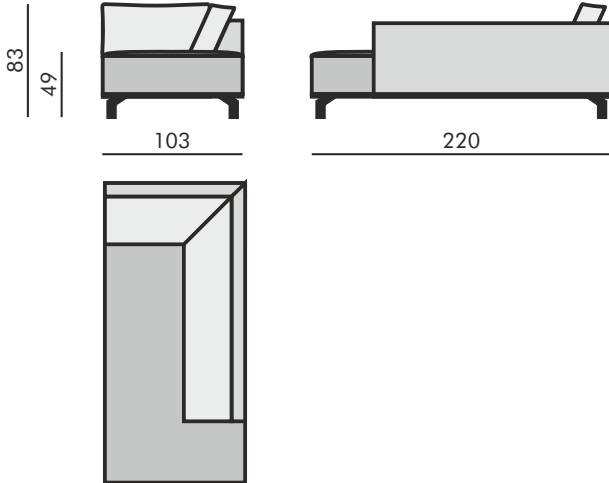

BROOKLYN

* CAN CHOOSE LEFT OR RIGHT SIDE OF THE ARMREST

- A. SEAT FILLING
- B. BACK FILLING
- C. FRAME SPRINGS/BELTS
- D. FRAME MATERIAL
- E. BACK MATERIAL
- F. UPHOLSTERY
- G. LEGS

- A. POLYURETHANE FOAM T3045 AND HR3536, BOXSPRING, SILICONE BALLS LUX MIXED WITH FOAM STICKS
- B. SILICONE BALLS LUX MIXED WITH FOAM STICKS
- C. SPRINGS
- D. SOLID BEECH WOOD
- E. WOOD BASED ELEMENTS (CHIPBOARD, FIBREBOARD) OF FRAME
- F. FABRIC AND/OR LEATHER

- G. METAL LEGS
- H: 14CM

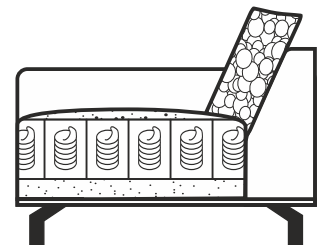

MODALTO RESERVES THE RIGHT TO CHANGE CONSTRUCTION OF PRODUCTS AND COMPONENTS USED DUE TO IMPROVING DURABILITY OF PRODUCT AND CUSTOMERS SATISFACTION WITHOUT ANY FURTHER NOTICE.
 EXPLICIT +/- 2CM TOLERANCE OF ALL AELEMENTS SIZES.

HO1

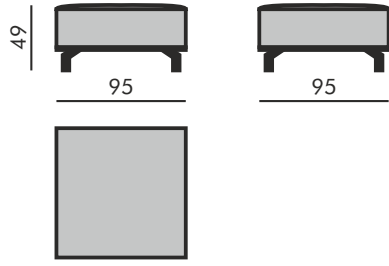

HO2

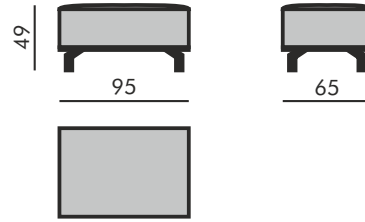

BROOKLYN

* CAN CHOOSE LEFT OR RIGHT SIDE OF THE ARMREST

- A. SEAT FILLING
- B. BACK FILLING
- C. FRAME SPRINGS/BELTS
- D. FRAME MATERIAL
- E. BACK MATERIAL
- F. UPHOLSTERY
- G. LEGS

- A. POLYURETHANE FOAM T3045 AND HR3536, BOXSPRING, SILICONE BALLS LUX MIXED WITH FOAM STICKS
- B. SILICONE BALLS LUX MIXED WITH FOAM STICKS
- C. SPRINGS
- D. SOLID BEECH WOOD
- E. WOOD BASED ELEMENTS (CHIPBOARD, FIBREBOARD) OF FRAME
- F. FABRIC AND/OR LEATHER

- G. METAL LEGS
- H: 14CM

